

## **DURACLUTCH INSTALLATION**

### **15-502 DCG1-RZR900-JX**

SVI, LLC REV5

PART #: 15-502

MODEL: DCG1-RZR900-JX

DESCRIPTION: MY13 RZR 900 4 JAGGED X

#### **KIT CONTENTS:**

- 1 10-080 PRIMARY CLUTCH
- 2 10-094 SECONDARY CLUTCH
- 3 321148 BELT
- 4 30-093 TOOL-BELT INSTALL
- 5 97-011 DECALS - CLUTCH HOUSING AND DASH 321148
- 6 OWNERS MANUAL SUPPLEMENT
- 7 WEIGHT CHART
- 8 DURACLUTCH WARRANTY
- 9 INSTALL INSTRUCTIONS 15-502 (THESE INSTRUCTIONS)

## DURACLUTCH INSTALLATION

1. Remove the Secondary clutch.
2. Install DURACLUTCH Secondary. If there is a snap ring behind the Secondary, remove it. Tighten bolt to 48 ft-lbf.
3. Remove Primary clutch bolt. Remove the Primary clutch with a puller (SVI 25-147). Greasing the end of the puller slightly will aid in removal. Do not get grease on any clutch components.
4. Clean the engine tapered shaft and Primary clutch bore with alcohol or degreaser. Do not lubricate.
5. Slip the belt into the Primary and over the Secondary.
6. Install DURACLUTCH Primary with shoulder washer as shown. DO NOT USE the O.E. flat washer. It may interfere with the primary cover. Tighten bolt to 60 ft-lbf.

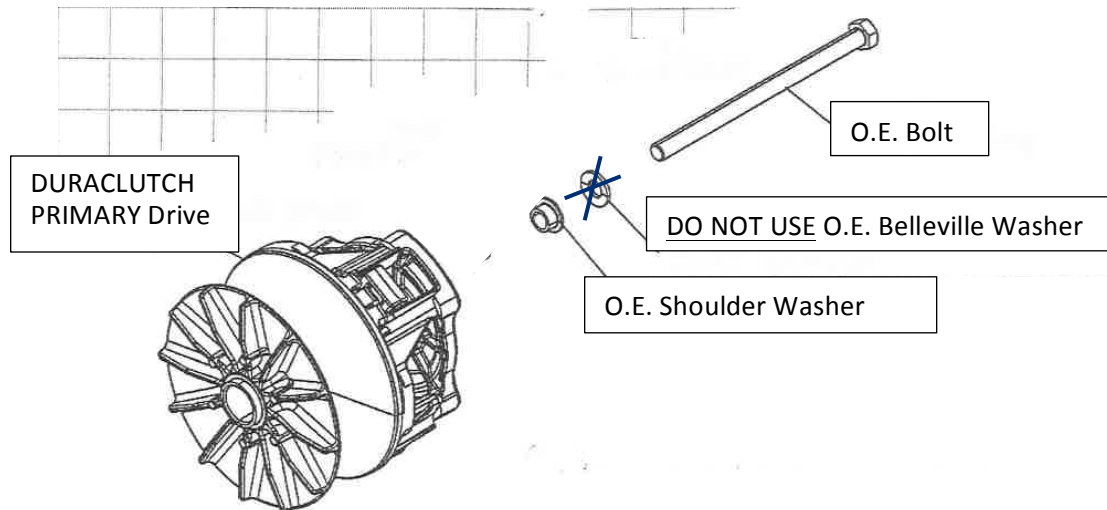

O.E. = Original Equipment

7. Install the belt as follows if the Primary and Secondary are already installed. Place Belt in the Primary and open the Secondary sheaves with the Belt Installation Tool provided (see photo). Roll belt into the Secondary sheaves.



8. Set belt tension. Place transmission in PARK! APPLY FOOT BRAKE TO INSURE VEHICLE REMAINS STATIONARY. Apply slight throttle to turn Secondary.
9. Install outer clutch housing. Insure seal is good or replace. The DURACLUTCH primary is slightly larger than the original equipment primary. To insure the primary does not rub against the cover push up and back on the housing while lightly snugging the bottom screws. Then tighten the top rear screw followed by the other top screws. Then tighten all remaining screws including the bottom screws evenly. After starting the engine if you hear the primary rubbing, push on the cover while the engine is running in different directions to see which way will eliminate the rubbing. Stop the engine and loosen the housing screws and retighten using the above sequence while pushing on the cover in the direction that eliminated the rubbing. If this does not eliminate the rubbing try installing a new gasket and go through the bolt tightening sequence again. If you cannot eliminate the rubbing the cover is heat warped and you may have to install a new cover and perhaps a new back plate. You may also try using a heat gun to remove heat sag in the cover.

#### DECALS

10. Apply two decals as shown – one on the clutch housing and one on the dash. Clean surface with alcohol or similar non-harsh solvent. Decal application is important to alert service technicians that the standard Polaris clutches have been replaced.

