

DURACLUTCH INSTALLATION

15-507 DCG1-RANGER800-FS

SVI, LLC REV4

PART #: 15-507

MODEL: DCG1-RANGER800-FS

DESCRIPTION: RANGER 800 FULL SIZE ALL MODELS EXCEPT RANGER 800 6X6

KIT CONTENTS:

- 1 10-071 PRIMARY CLUTCH
- 2 25-164 SHOULDER WASHER, SUPERSEDES 90-019
- 3 10-055 SECONDARY CLUTCH
- 4 10-059 TORQUE STOP TRANSAXLE MOUNT
- 5 3211162 BELT
- 6 30-093 TOOL-BELT INSTALL
- 7 97-008 DECALS - CLUTCH HOUSING AND DASH 3211162
- 8 OWNERS MANUAL SUPPLEMENT
- 9 WEIGHT CHART
- 10 DURACLUTCH WARRANTY
- 11 INSTALLATION INSTRUCTIONS 15-507 (THESE INSTRUCTIONS)

NOTE REGARDING THE TORQUE STOP AND ENGINE MOUNTS:

A torque stop is supplied with this DURACLUTCH kit. Installing the torque stop is optional. Installation is recommended if optimum acceleration and engine braking are desired and especially if the RANGER is used to carry or pull heavy loads.

How the torque stop works: The RANGER 800 engine and transmission are mounted independent of each other. The engine is rubber mounted for vibration isolation. When torque is transmitted through the belt the rubber mounts flex and the engine is pulled toward the secondary clutch on the transmission tending to loosen the belt. The purpose of the torque stop is to limit the engine movement when accelerating and engine braking. The torque stop maintains belt tension and keeps the belt from slipping.

Engine mounts: Now is a good time to check motor mounts (4 places) to insure none are broken (separated) or vehicle performance will be adversely affected. The best way to do this is to use a pry bar to move the engine away from the mount. If the mount is broken it will separate when you move the engine away from the mount. Replace any broken motor mounts.

If you decide to install the torque stop we recommend installation now, since much of the required disassembly is already done. If not installing at this time skip to DURACLUTCH INSTALLATION.

TORQUE STOP INSTALLATION:

1. Remove clutch housing back and install the torque stop bracket with the transaxle mounting bolts as shown. Torque nuts to 32 ft-lbf.

PROCEEDURE TO SET TORQUE STOP:

2. If needed trim hose to clear pad (no need to remove hose to trim) or loosen the hose clamp and move the hose up. Tighten the rubber pad against engine so the pad just touches the engine on the bottom side of the pad. Hold rubber pad from turning and lock jam nut. The upper part of the pad should not be tight against the engine.

Note: If the pad is tight against the engine when idling or in steady state running, undesirable engine vibration will be felt. When the engine is accelerating or in engine braking mode it should pull back against the rubber pad to keep the belt tight so it won't slip.

3. When reinstalling clutch housing back insure seals are good or replace.

PHOTO OF TORQUE STOP INSTALLATION WITH CLUTCH HOUSING BACK REMOVED

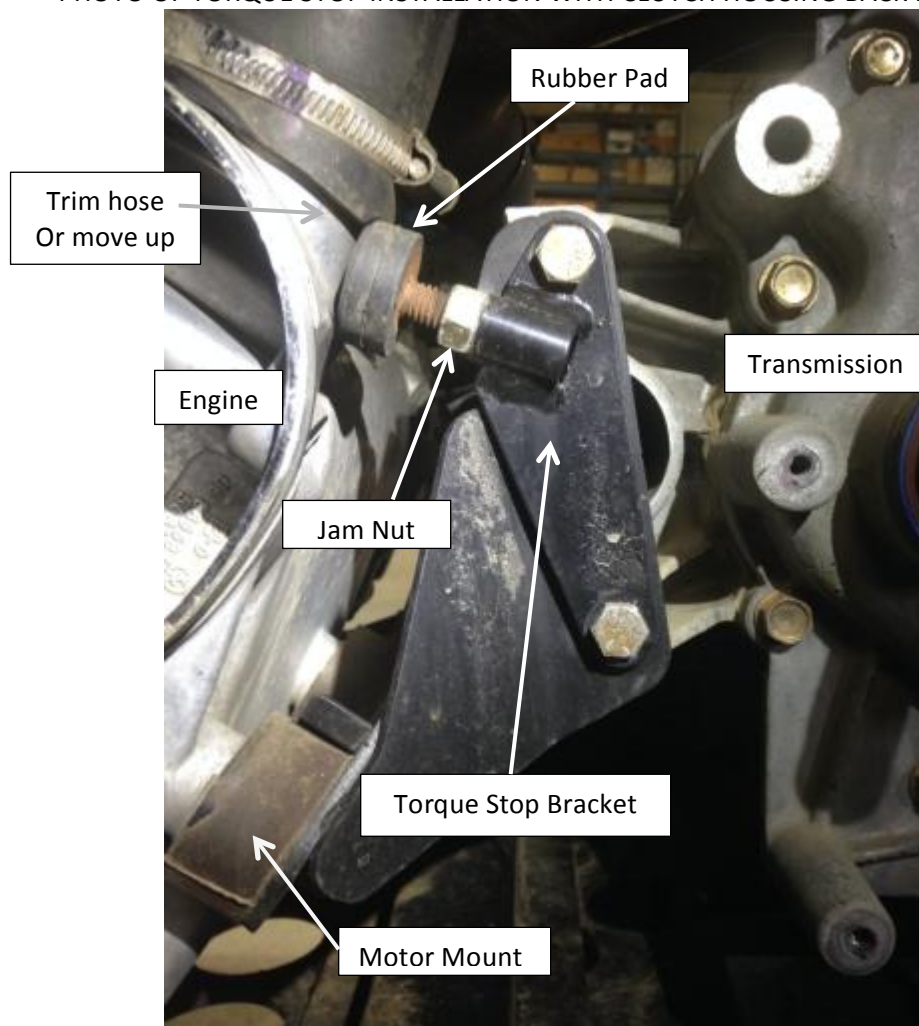

MODEL OF TORQUE STOP INSTALLATION WITH CLUTCH HOUSING BACK REMOVED

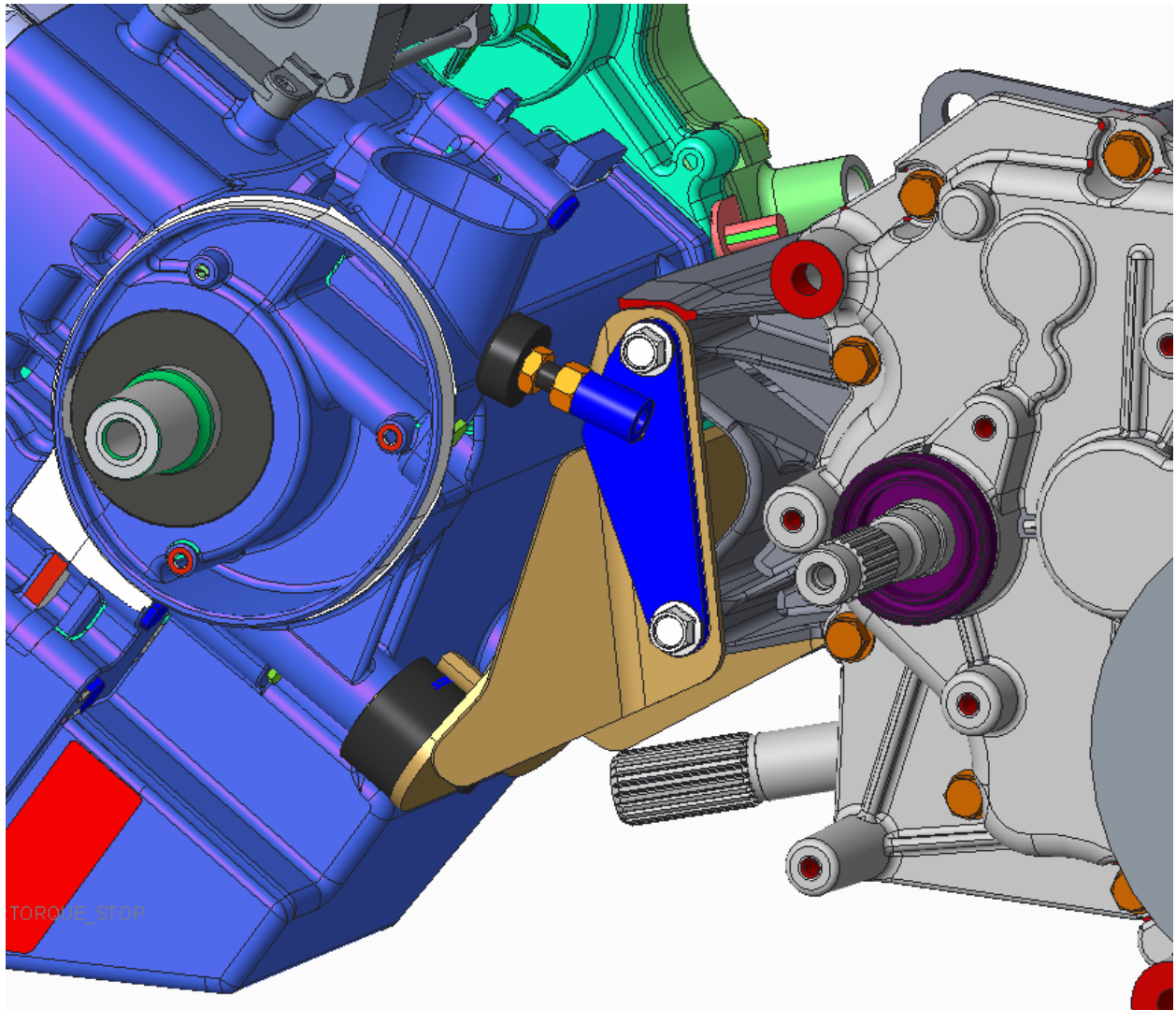

DURACLUTCH INSTALLATION

1. Remove the Secondary clutch.
2. Install DURACLUTCH Secondary. Tighten bolt to 17 ft-lbf.
3. Remove Primary clutch bolt. Remove the Primary clutch with a puller (SVI 25-147). Greasing the end of the puller slightly will aid in removal. Do not get grease on any clutch components.
4. Clean the engine tapered shaft and primary clutch bore with alcohol or degreaser. Do not lubricate.
5. Slip the belt into the Primary and over the Secondary.
6. Install DURACLUTCH Primary with shoulder washer as shown. DO NOT USE the O.E. flat washer. It may interfere with the primary cover. Tighten bolt to 60 ft-lbf.

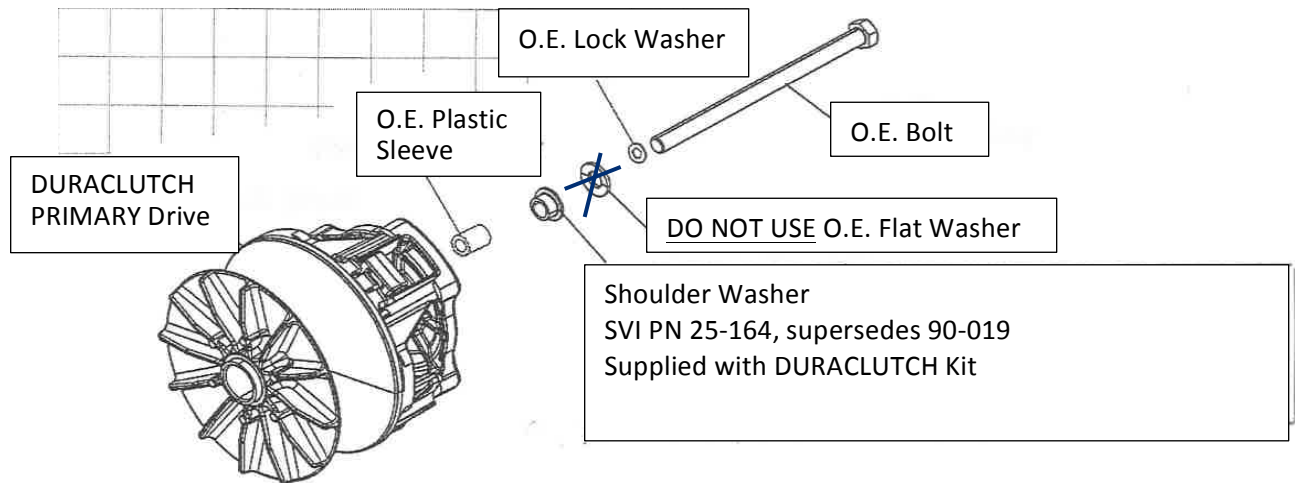

O.E. = Original Equipment

7. Install the belt as follows if the Primary and Secondary clutches are already installed, Place belt in the Primary and open the Secondary sheaves with the Belt Installation Tool provided (see photo). Roll the belt into the Secondary sheaves.



8. Set belt tension. Place transmission in neutral and set park brake. APPLY FOOT BRAKE TO INSURE VEHICLE REMAINS STATIONARY. Apply slight throttle to turn Secondary
9. Install outer clutch housing. Insure seal is good or replace. The DURACLUTCH primary is slightly larger than the original equipment primary. To insure the primary does not rub against the cover push up and back on the housing while lightly snugging the bottom screws. Then tighten the top rear screw followed by the other top screws. Then tighten all remaining screws including the bottom screws evenly. After starting the engine if you hear the primary rubbing, push on the cover while the engine is running in different directions to see which way will eliminate the rubbing. Stop the engine and loosen the housing screws and retighten using the above sequence while pushing on the cover in the direction that eliminated the rubbing. If this does not eliminate the rubbing try installing a new gasket and go through the bolt tightening sequence again. If you cannot eliminate the rubbing the cover is heat warped and you may have to install a new cover and perhaps a new back plate. You may also try using a heat gun to remove heat sag in the cover.

DECALS

10. Apply 2 decals as shown – 1 on the clutch housing and 1 on the dash. Clean surface with alcohol or similar non-harsh solvent. Decal application is important to alert service technicians that the standard Polaris clutches have been replaced.

