

DURA CLUTCH INSTALLATION

15-504 DC-RZR900-C

SVI, LLC REV18 03MAR2021

PART #: 15-504

MODEL: DC-RZR900-C

DESCRIPTION: MY16-19 RZR 900 ALL MODELS

KIT CONTENTS:

1. 10-128 ASM-DCPRIM WT10-099 SPR50-001
2. 25-146 SHOULDER WASHER
3. 75-047 SCREW - CLUTCH
4. 99-007 TOOL-12MM BIT SOCKET 1/2 DRIVE (SUBSTITUTE 99-024 TOOL-12MM BIT SOCKET 3/8 DRIVE)
5. 10-192 ASM-DC SECONDARY 9.5 PREM ROLL (supersedes 10-117 and 10-156)
6. 90-030 QTY 1 WASHER-SECONDARY SHIM. SEE STEP 2
7. 75-058 SECONDARY SCREW-M10X1.25X65 8.8 HX ZY
8. 7556130 SECONDARY WASHER-.406X1.25X.125 BELLE-Y
9. 35-024 BELT (substitute 3211148)
10. 30-091 TOOL-BELT INSTALL
11. 97-017 DECAL-DC CLUTCH HOUSING DASH 35-024
12. OWNERS MANUAL SUPPLEMENT
13. WEIGHT CHART
14. DURA CLUTCH WARRANTY
15. INSTALLATION INSTRUCTIONS 15-504 (THESE INSTRUCTIONS)

DURACLUTCH INSTALLATION

1. Remove the clutch housing cover and the Secondary clutch.
2. Install the DURACLUTCH Secondary. Use the Secondary bolt and beveled washer supplied with this kit. Do not use O.E. (Original Equipment) hardware. Place the 90-030 shim washer on the transmission shaft. Place a drop of BLUE Loctite on the secondary bolt. Tighten the Secondary bolt to 45 ft-lbf.

Secondary shaft shown with one shim washer.



3. Remove Primary clutch bolt. Remove the Primary clutch with puller SVI 99-012 (PII 28772085). Greasing the end of the puller slightly will aid in removal. Do not get grease on any clutch components.
4. Clean the engine tapered shaft and Primary clutch bore with alcohol or degreaser. Do not lubricate.
5. Slip the belt into the Primary and over the Secondary.
6. Install DURACLUTCH Primary with hardware provided as shown. Tighten bolt to 60 ft-lbf.

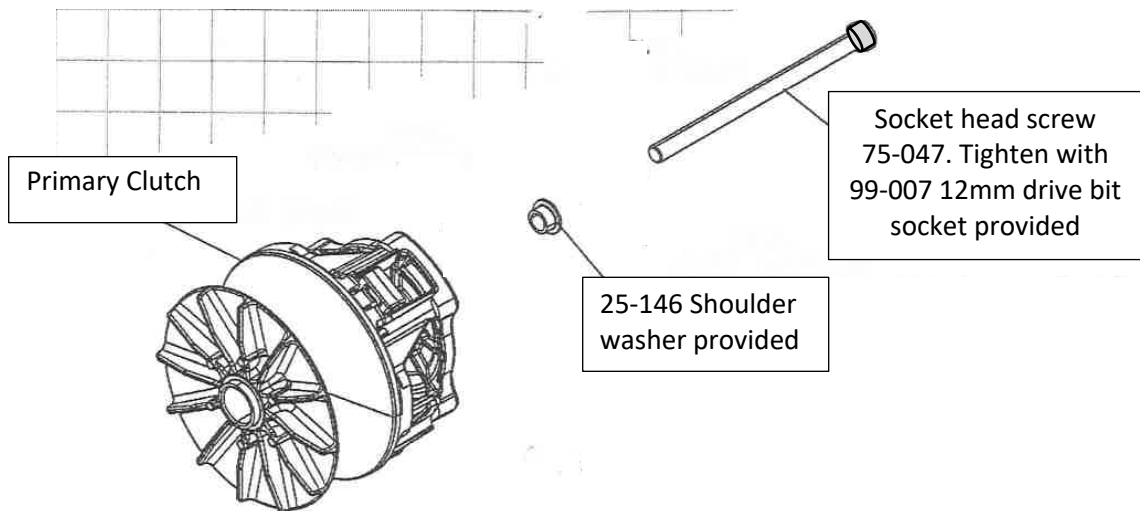

Do not use original equipment screw or hardware.

7. Install the Belt as follows if the Primary and Secondary are already installed. Place Belt in the Primary and open the Secondary sheaves with the Belt Installation Tool provided (see photo). Roll belt into the Secondary sheaves.



8. Preliminary installation check.
- A. Put transmission in PARK. APPLY FOOT BRAKE TO ENSURE VEHICLE REMAINS STATIONARY.
 - B. Start the engine and apply slight throttle to engage Primary clutch packs to rotate clutches and seat belt in sheaves. The clutches may rotate slowly when in PARK (or NEUTRAL). This is normal.
 - C. Drop throttle. With engine at idle shift transmission to HI, LO and REV. The transmission should shift smoothly.
9. Install outer clutch housing. Insure seal is good or replace. The DURACLUTCH primary is slightly larger than the original equipment primary. To insure the primary does not rub against the cover push up and back on the housing while lightly snuging the bottom screws. Then tighten the top rear screw followed by the other top screws. Then tighten all remaining screws including the bottom screws evenly. After starting the engine if you hear the primary rubbing, push on the cover while the engine is running in different directions to see which way will eliminate the rubbing. Stop the engine and loosen the housing screws and retighten using the above sequence while pushing on the cover in the direction that eliminated the rubbing. If this does not eliminate the rubbing try installing a new gasket and go through the bolt tightening sequence again. If you cannot eliminate the rubbing the cover is heat warped and you may have to install a new cover and perhaps a new back plate. You may also try using a heat gun to remove heat sag in the cover.
10. Drive vehicle for 5 miles to break-in DURACLUTCH kit components.
NOTE: If the transmission still shifts hard after break-in there are likely issues other than drag in the clutches. See your dealer or call DURACLUTCH service (218-967-8205).

DECALS

11. Apply two decals as shown – on the clutch housing and on the dash. Clean surface with alcohol or similar solvent. Decal application is important to alert service technicians that the standard Polaris clutches have been replaced.

