

DURA CLUTCH INSTALLATION

15-520 DC-RANGER1000-Z

SVI, LLC REV6 03MAR2021

KIT PART #: 15-520

MODEL: DC-RANGER1000-Z

DESCRIPTION: MY18-21 RANGER XP1000, MY19-21 RANGER CREW XP1000. These models have the Polaris P90X Clutch. Does not fit MY20,21 RANGER 1000s. These models have the Polaris P190X CLUTCH.

KIT CONTENTS:

1. 10-174 ASM-DCPRIM WT10-149 SPR50-001
2. 35-024 BELT
3. 25-146 SHOULDER WASHER
4. 75-047 SCREW-CLUTCH
5. 99-007 TOOL-12MM BIT SOCKET 1/2 DRIVE (SUBSTITUTE 99-024 TOOL-12MM BIT SOCKET 3/8 DRIVE)
6. 99-013 TOOL-T60 BIT SOCKET 1/2" DRIVE
7. 99-012 PULLER-MOD DC P90X P190X PRIMARY
8. 7557060 QTY 3 SECONDARY SHIM-RING 23.25X32.25X0.5
9. 97-017 DECAL-DC CLUTCH HOUSING DASH 35-024
10. OWNERS MANUAL SUPPLEMENT
11. WEIGHT CHART
12. DURA CLUTCH WARRANTY
13. INSTALL INSTRUCTIONS 15-520 (THESE INSTRUCTIONS)

DURACLUTCH INSTALLATION

Note: To aid in this installation we recommend the installer watch the DURACLUTCH 15-520 Kit installation video produced by SVI. The video can be found here https://www.youtube.com/watch?v=u9oRnH_A0fM&t=314s. It is titled "Installation of a DURACLUTCH Model 15-520". The following written instructions contain the basics, the videos are comprehensive.

1. Remove the clutch housing cover. Recommended tool: 8mm socket with flex drive extension.
2. Remove the Polaris primary outer movable sheave assembly. Pull off by hand holding the central shaft in place with your thumb. Move around the clutch, with a pulling and rocking motion.



3. Pull the Polaris primary fixed sheave from the engine crankshaft using the 99-012 puller provided.



4. Clean the engine tapered shaft and DURACLUTCH Primary clutch bore with alcohol or degreaser. Do not lubricate.
5. Install the DURACLUTCH Primary with hardware provided as shown. Tighten bolt to 60 ft-lbf.

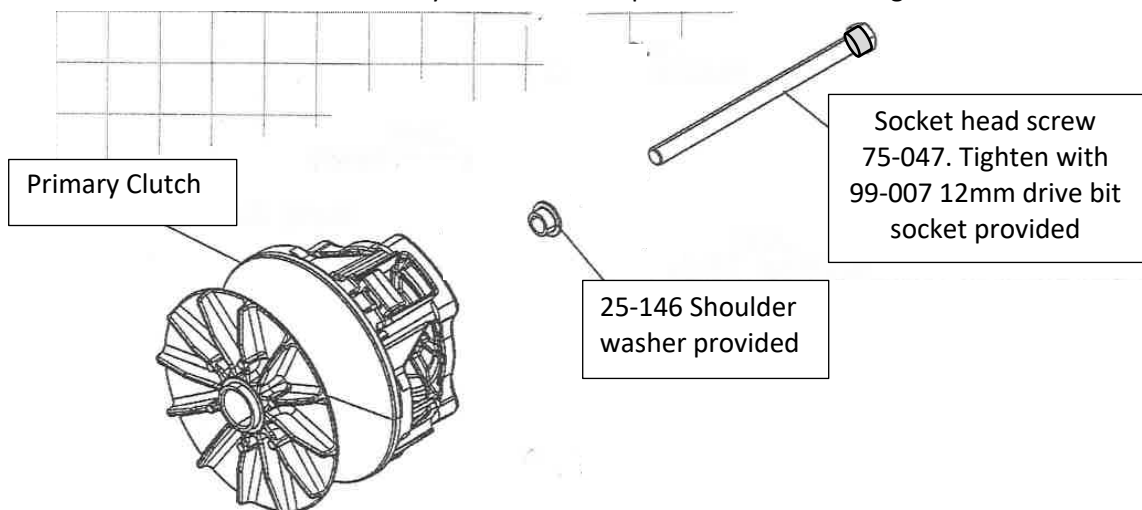

Do not use original equipment screw or hardware.

6. Remove the secondary screw and add the 3 provided 7557060 secondary shim washers under the outer screw washer. This is to align the secondary with the DURACLUTCH Primary. Re-install the screw using blue Loctite. Tighten bolt to 45 ft-lbf. Note: there may be 1 to 8 shim washers already in place. There are usually 4 to 5.



7. Install the belt. Place the RANGER transmission in Park. Use the L shaped tool supplied in the vehicle tool kit. Thread the tool all the way into the secondary to spread the sheaves to install the belt. Slip the belt into the primary and roll the belt into the secondary. REMOVE THE TOOL! Roll the primary and secondary with the belt installed to seat the belt in the sheaves.



8. Preliminary installation check.
- A. Put transmission in PARK. APPLY FOOT BRAKE TO INSURE VEHICLE REMAINS STATIONARY.
 - B. Start the engine and apply slight throttle to engage the Primary clutch packs to rotate clutches and seat the belt in the sheaves. The clutches may rotate slowly when in PARK (or NEUTRAL). This is normal.
 - C. Drop the throttle. With the engine at idle shift transmission to HI, LO and REV. The transmission should shift smoothly.
9. Re-install the outer clutch housing. Insure the housing seal is good or replace. Start the housing screws into the threads by hand to insure they are not cross-threaded. Then tighten the screws in opposite sequence around the cover. Tighten to 35 in-lbf. Recommended tool: 8mm socket with flex drive extension.

DECALS

10. Apply two decals as shown – on the clutch housing and on the dash. Clean surface with alcohol or similar solvent. Decal application is important to alert service technicians that the stock Polaris clutches have been replaced.

